



Service Manual

Washing machine

Toploader

AWT 8123 D

Model Version		Page
	AWT 8123 D 8561 812 10430	
	Technical data	2 - 3
	Spare part list	4
	Exploded view	5 - 6
	Wiring diagram	7
	Circuit diagram	8
	Program chart	9 - 14
	Text/Legend	15 - 18
	Family	A4

Technical data

Dimensions

Height	85	cm
Width	40	cm
Depth	60	cm

Weight

Without packing	62	kg
-----------------	----	----

Main connection

Voltage	230	V
Frequency	50	Hz
Power consumption	2.3	kW
Fuse rating	10	A

Drum

Volume	42	l
Wash spin	54	rpm
Ramp spin	95	rpm
Speed spinning	1200	rpm

Capacity of dry laundry

Cotton/coloured laundry	5/ 4,5	kg
Cotton rapid	3	kg
Easy care	2.5	kg
Easy care rapid	1.5	kg
Delicate	1.5	kg
Wool	1	kg

Pressostat

Nominal current

Contacts:

11 - 12	4 (4) A	24V DC/3 mA
11 - 14	4 (4) A	24V DC/3 mA
21 - 12	4 (4) A	24V DC/3 mA
21 - 24	16 (4) A	24V DC/3 mA
21 - 26	1 (1) A	24V DC/3 mA

Contactsystem:

11 - 12 - 14	jump contacts
21 - 22 - 24	jump contacts
21 - 26	slow action contacts

Door lock (5-pol.)

Lock time (0-85°C)	<5"
Unlock time after 30" on	70± 30"
Nominal voltage	250 V
Nominal current contacts:	
4 - 5	16 (4) A

Heating element

Kind of heating	Tubular heating element with NTC-sensor	
Nominal voltage	230	V
Nominal power	2050	W
Heat conductor resistance	22-28	Ω
Resistance NTC:		
0°C	35.9	kΩ
30°C	9.8	kΩ
40°C	6.9	kΩ
50°C	4.8	kΩ
60°C	3.4	kΩ
70°C	2.4	kΩ
90°C	1.7	kΩ

Water inlet valve

Water temperature max.	80	°C
Rated flow > 1 bar	8	l/min.
Pressure range	0.2-10	bar
Nominal voltage	220-240	V
Frequency	50	Hz
Starting voltage 0.2-10 bar	160	V
Nominal current	40	mA
Nominal power	8.8± 10%	VA
Nominal resistor (20°C)	3.8± 10%	Ω

Flowmeter

Type	1458 00
Switch power nominal	25± 20% mW
Switch current nominal	5 ± 20% mA
Switch voltage nominal DC	5 ± 10% V
Contact resistance	< 200 mΩ

Drain pump (synchronous)

Nominal voltage	230	V
Nominal current	0.3	A
Nominal consumption	34	W
Frequency	50	Hz
Resistor (coil)	155 ± 7%	Ω
Motor protection	170	°C
Capacity (1.25m height)	15± 2	l/min

Technical data

Program timer

Type	Electronic	
Fab.	Omega (Timer A4)	
Nominal voltage	230	V
Frequency	50	Hz
Ambient temperature	to 70	°C
Storage temperature	to 85	°C

Motor

Type	MCA 52/64 - 148 / ALE	
	i = 1 :13.4	
Pulley diameter	21.4	mm
Resistance:		
Contact 1 - 2	68.7	± 7% Ω
Collector directly	1.90	± 7% Ω
Field winding 2 - 3	2.17	± 7% Ω
Field winding 1 - 3	1.35	± 7% Ω
Tacho pole pairs	16	
Sense of rotation in spinning, in view on pulley side	clockwise	

Radio interference supression

Nominal voltage	230	V
Nominal capacity	1μ FX1+2x22nFY	
Nominal inductance	2 x 1	mH
Nominal resistance	470	kΩ

Temperature selector switch

Positions	7
-----------	---

Spin speed selector switch

Positions	7
-----------	---

Program selector switch

Positions	11
-----------	----

Option

Drum-up	DU
---------	----

Push button switch

Start stop	SST
Prewash	SPW
Intensive rinse	SRI
Rinse hold	SRS
Spin speed reduction	SSR
Start delay	STD
Remaining time	RT

Spare part list

Model AWT 8123 D
Service No. 856181210430
Version 856181210430

Pos. No.	12NC Code	Description
002 0	4812 459 38016	Flap
002 1	4812 459 38017	Hinge flap
004 0	4812 440 19496	Drip tray assy
010 0	4812 458 48349	Door frame inner
010 1	4812 440 19566	Frame Top
011 0	4812 462 48054	Foot
012 1	4812 528 78035	Lever f. trolley
012 3	4812 528 78038	Wheel front
012 4	4812 528 78039	Axle front trolley
012 6	4812 528 78037	Cam f. trolley
012 7	4812 528 78044	Trolley kit front
012 8	4812 528 78046	Foot adjustable rear
021 0	4812 440 19534	Front,panel
022 0	4812 440 19492	Side panel right
022 1	4812 440 19493	Side panel left
024 0	4812 440 19495	Rear panel
040 0	4812 417 18815	Hinge bolt
061 0	4812 466 88466	Counter weight left
061 1	4812 466 88465	Counter weight right
065 0	4812 310 18454	Insulation right
065 1	4812 310 18455	Insulation left
065 2	4812 310 18456	Insulation left
065 3	4812 310 18457	Insulation front
081 4	4812 529 18042	Shock absorber kit
100 1	4812 440 19489	Lid outer
100 3	4812 440 19512	Lid inner cpl.
100 5	4812 440 19535	Lid
110 4	4812 440 19553	Handle cpl.
191 1	4812 492 98012	Strap f. Doorbellow
191 2	4812 310 18484	Kit Bellow (MH) 5cm
200 0	4812 418 18222	Tub
201 0	4812 440 19487	Cover f. Tub
220 0	4812 418 18227	Drum porte 210 mm
223 0	4812 418 48474	Drum lifter
223 1	4812 418 48475	Drum lifter 84mm
271 0	4812 358 18158	Belt
272 0	4812 528 88077	Pulley 298 (MH)
290 0	4812 532 68069	Seal f. Tub
301 0	4812 452 10169	Control panel
321 0	4812 452 10138	Insert panel 13 LEDS
331 0	4812 412 58818	Knob Timer
331 1	4812 412 58817	Knob Options
332 0	4812 410 28578	Button on/off
332 1	4812 410 28579	Button Option
339 0	4812 413 58947	Adapter Shaft
339 1	4812 413 18241	Adapter
350 0	4812 214 58039	Display A4
400 0	4812 361 58133	Motor AC6 MCA 52 TF
421 0	4812 121 18142	Interf.filter 1,00 uF
430 0	4812 360 18385	Pump MH
451 0	4812 259 28703	Heating element with hole
451 1	4812 259 28692	Resistor,NTC
490 0	4812 321 18066	Cable,mains EU/2m
490 1	4812 321 18067	Strain relief
521 0	4812 282 18475	Control board

Pos. No.	12NC Code	Description
521 1	4812 323 18006	Actuator f. Distribution
571 0	4812 281 28393	Valve,magnet
581 0	4812 271 28389	Pressostat A4
581 1	4812 271 18011	Meter,flow OMEGA
623 3	4812 418 18224	Brake Kit-up
630 0	4812 271 38364	Door lock
701 0	4812 530 28863	Hose cold fill
702 2	4812 530 28882	Hose Flowm./Nozzlebox
702 3	4812 530 28864	Hose valve/flowmeter
707 0	4812 526 48044	Nozzle box cold cpl.
712 4	4812 418 68162	Siphon f. softener
712 5	4812 418 68163	Siphon f. bleach
712 6	4812 418 68164	Clip SOAP DISPENSER
712 9	4812 418 68168	Soap dispenser kit
717 0	4812 323 18012	Cam Actuator A4
717 1	4812 323 18023	Lever adjustment A4
717 2	4812 323 18009	Lever,arm
753 0	4812 418 68182	Chamber,air
754 0	4812 530 28859	Drainhose
754 1	4812 530 28832	Lock eco
754 2	4812 530 28829	Flange eco
781 0	4812 530 28861	Hose,draining
782 0	4812 530 28866	Hose Pressostat
787 0	4812 530 28865	Hose Air Exhaust
794 0	4812 530 58098	Gasket Airtrap
900 0	4812 290 68157	Strap SNP 8
900 1	4812 401 18431	Clamp to pump
900 2	4812 401 18432	Support Cable/Hose
900 3	4812 401 18449	Clamp Flowm. Hose
900 6	4812 400 18048	Pin
900 8	4812 401 18447	Clamp top frame
901 0	4819 401 18529	Clamp,hose
904 0	4812 401 18412	Stopper
910 0	4812 502 48347	Screw,selftap f. Lid
910 1	4812 502 38151	Screw 4x14
910 2	4812 502 48346	Screw 3.5X14
910 3	4812 502 18404	Screw
910 5	4812 502 18401	Screw M8X 35
910 6	4812 502 18399	Nut Push in M 8
910 7	4812 502 38152	Screw 4,8x19
910 8	4812 502 48348	Screw ST 4,2X 11
921 0	4812 400 18047	Washer
930 1	4812 492 48085	Torsions spring
930 2	4812 492 48086	Spring
930 3	4812 323 18011	Spring f. Lever
941 2	4812 310 18483	Bearing kit
953 0	4812 325 68001	Shaft seal
953 1	4812 520 28073	Ring counterface
953 2	4812 530 68017	O-Ring
962 0	4812 440 19497	Cover f. Motor
993 0	4812 530 28875	Bow

Exploded view

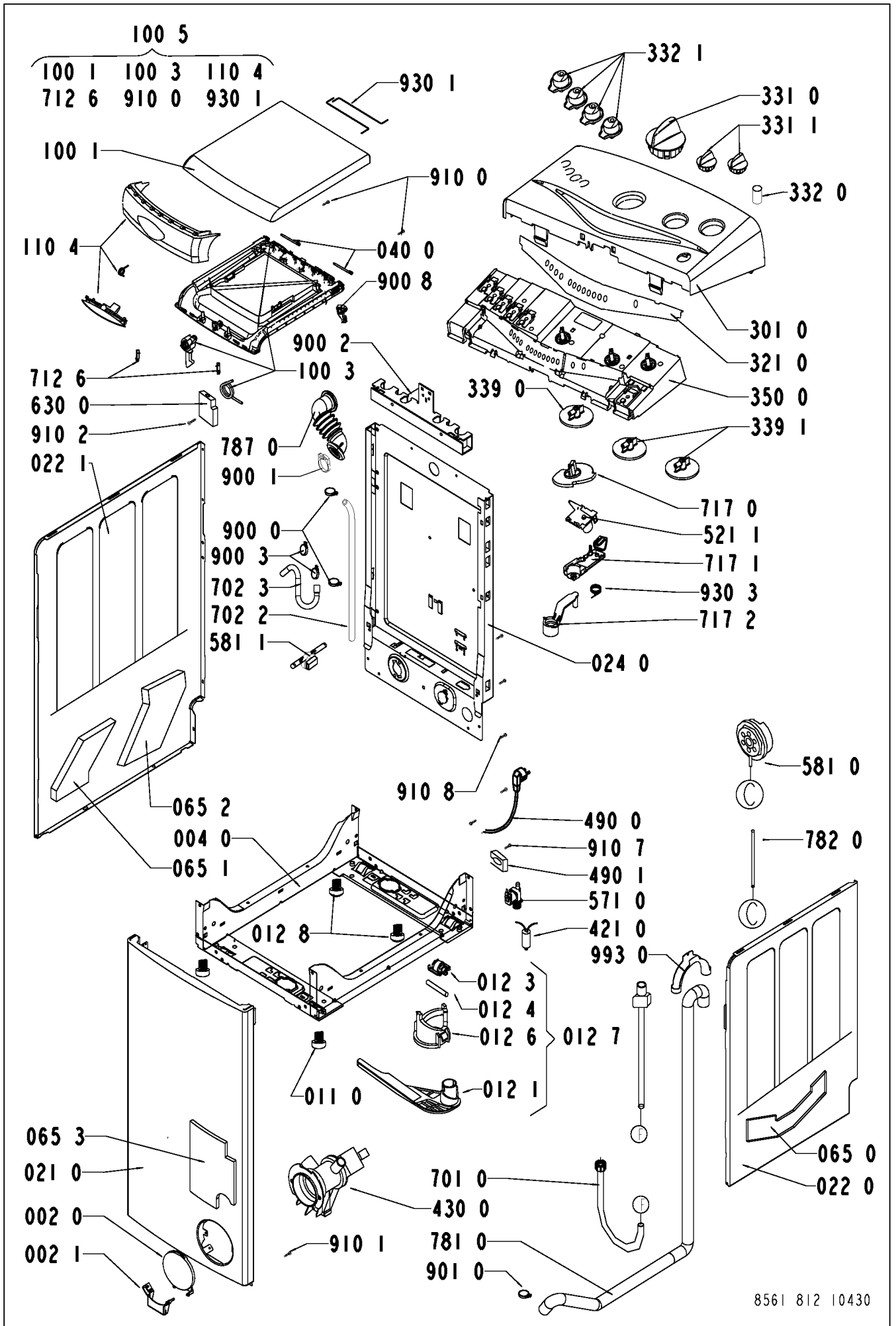

Exploded view

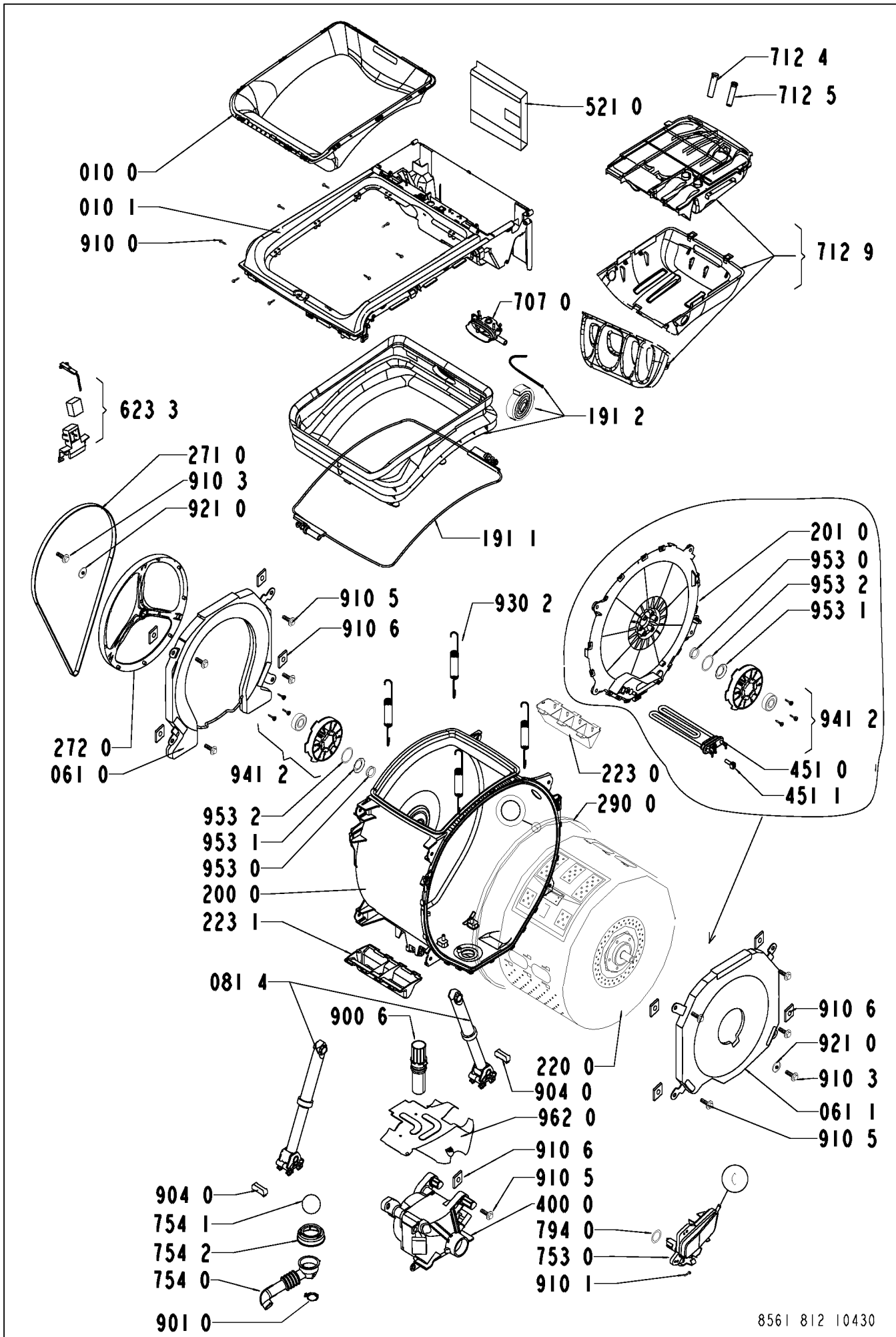

Wiring diagram

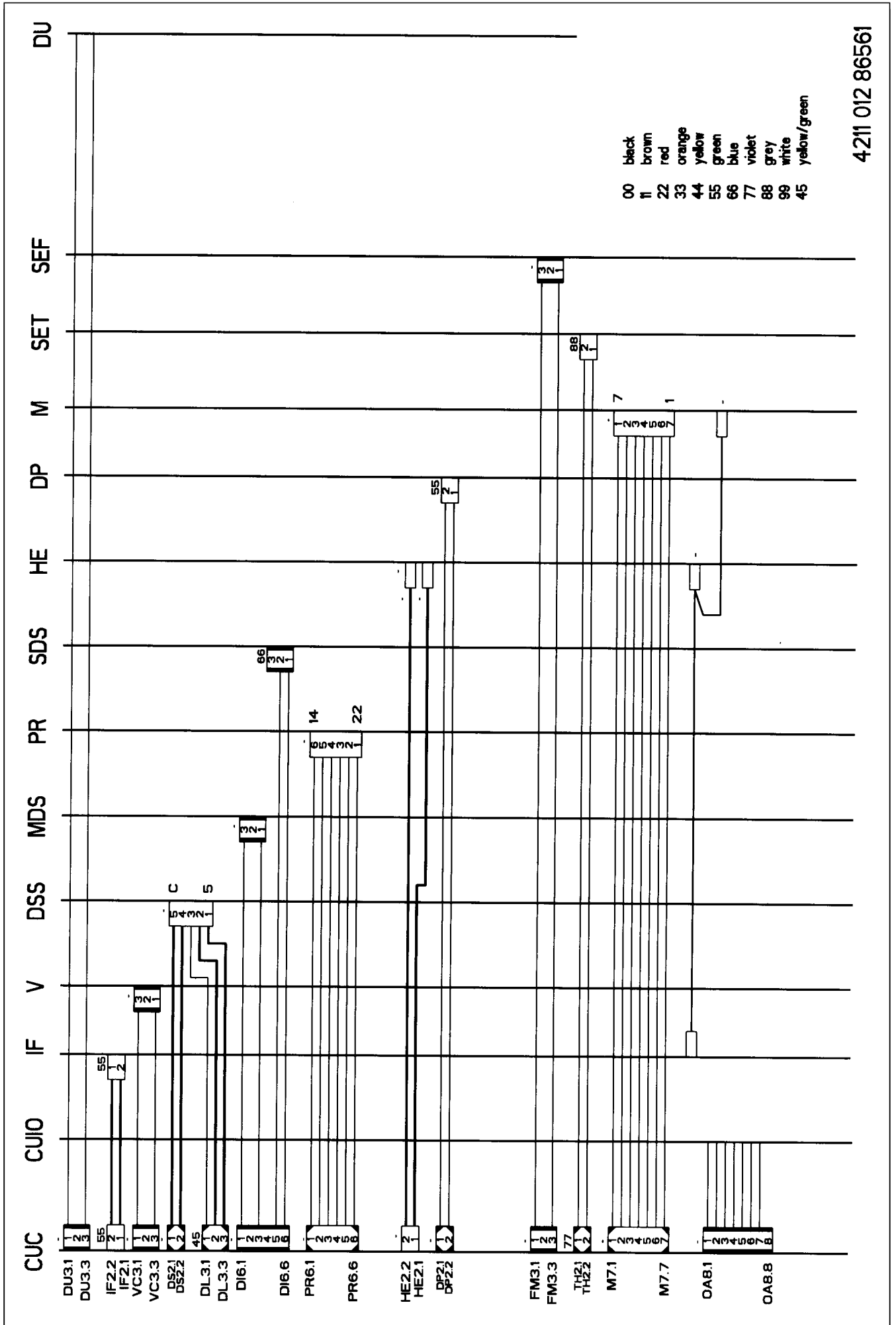

Circuit diagram

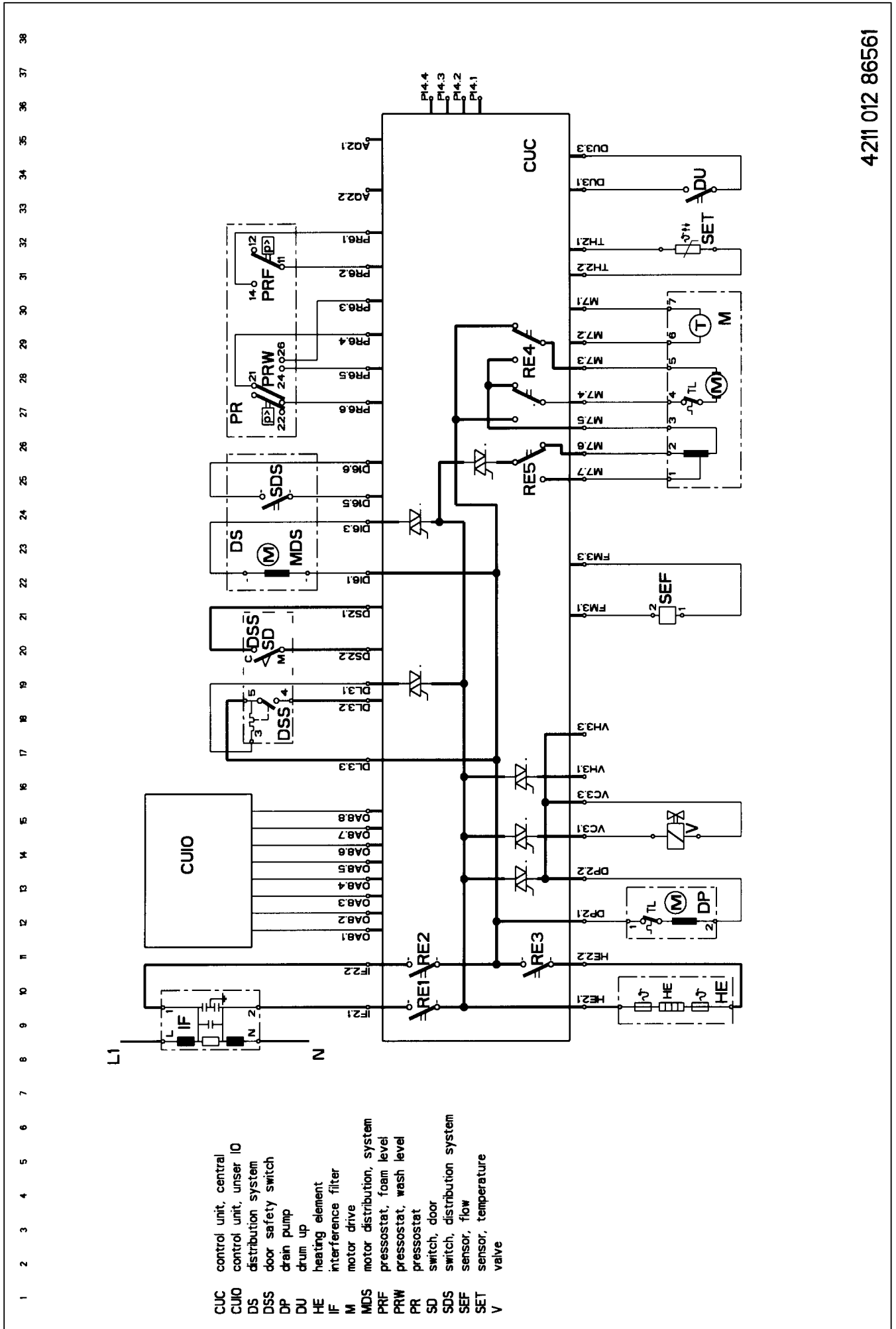

Program chart

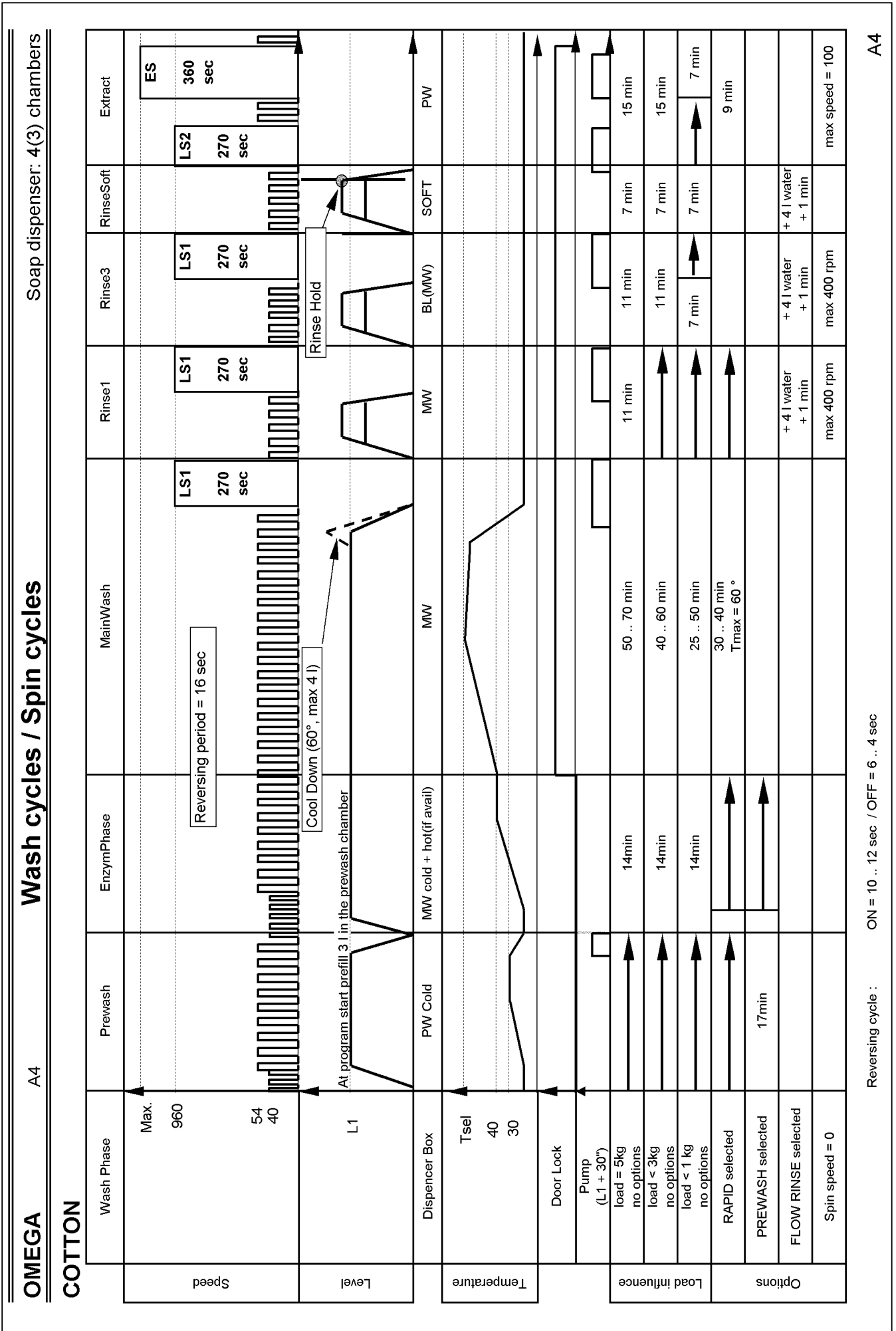

Reversing cycle : ON = 10 .. 12 sec / OFF = 6 .. 4 sec

A4

Program chart

Soap dispenser: 4(3) chambers

Wash cycles / Spin cycles

A4

Easy Care

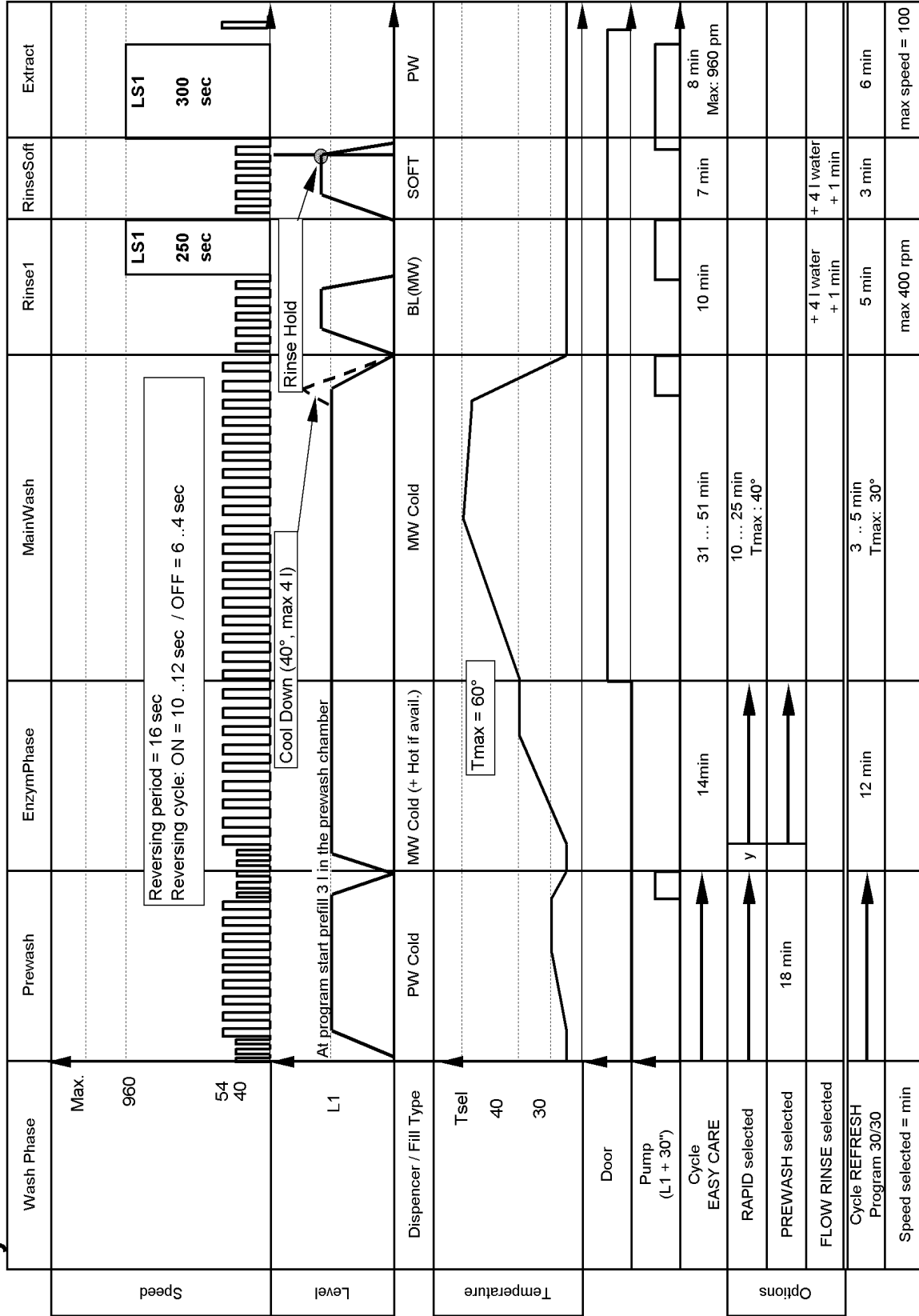

A4

Program chart

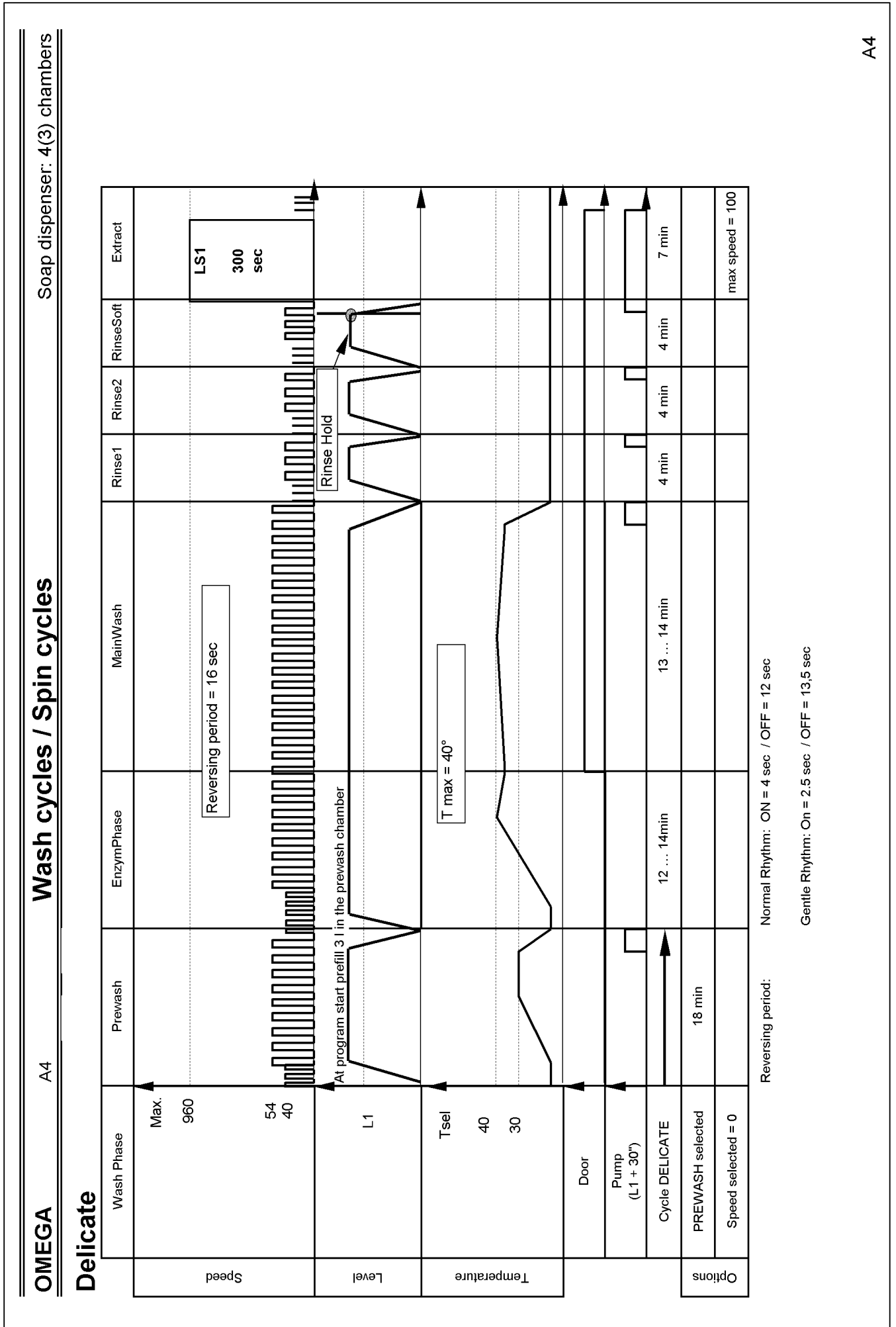

Program chart

Soap dispenser: 4(3) chambers

Wash cycles / Spin cycles

A4

OMEGA

Wool

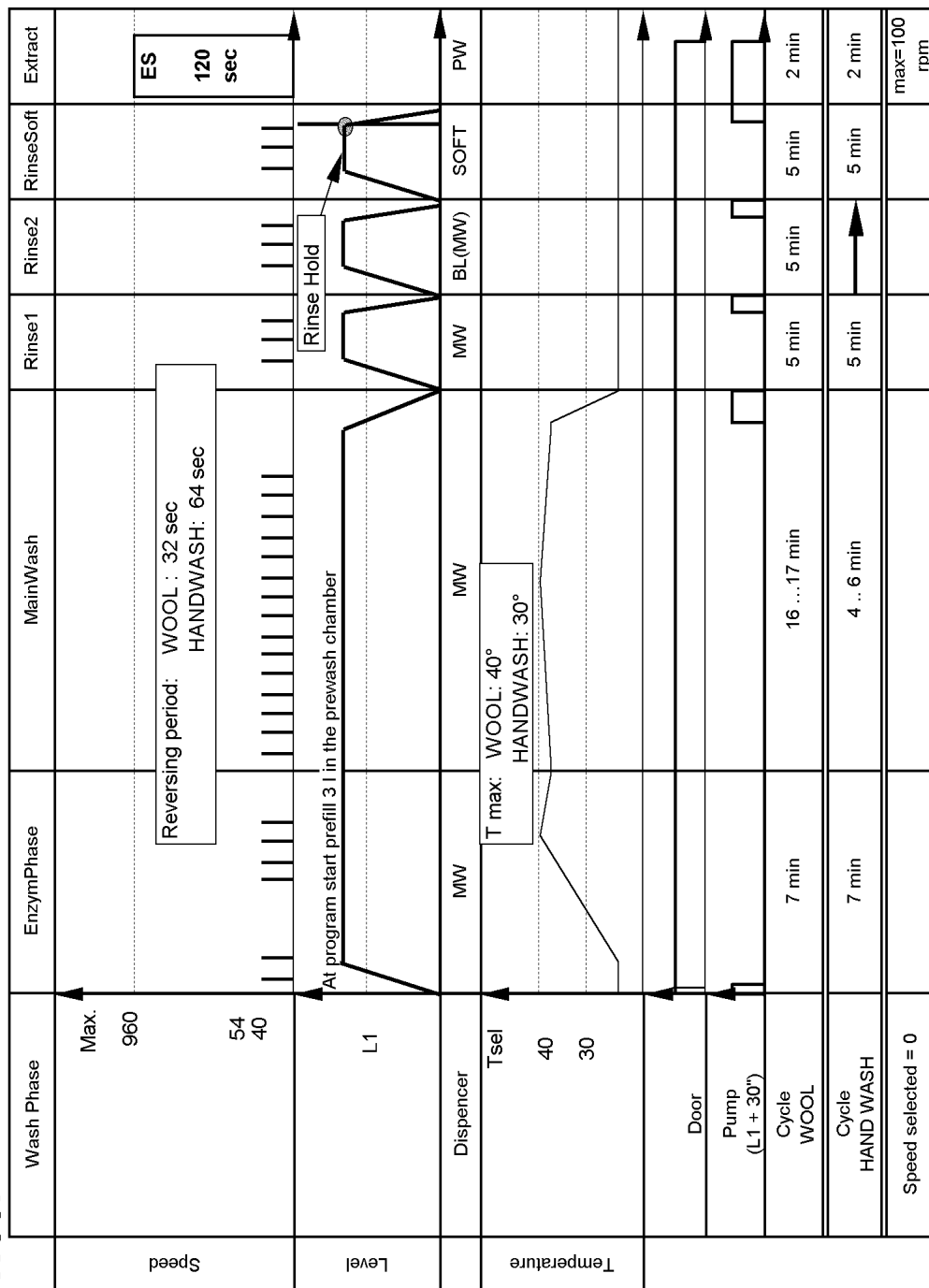

Reversing period: ON = 1,5 sec / OFF = 30 ... 62 sec

A4

Program chart

OMEGA

A4

Wash cycles / Spin cycles

Soap dispenser: 4(3) chambers

LS cycles

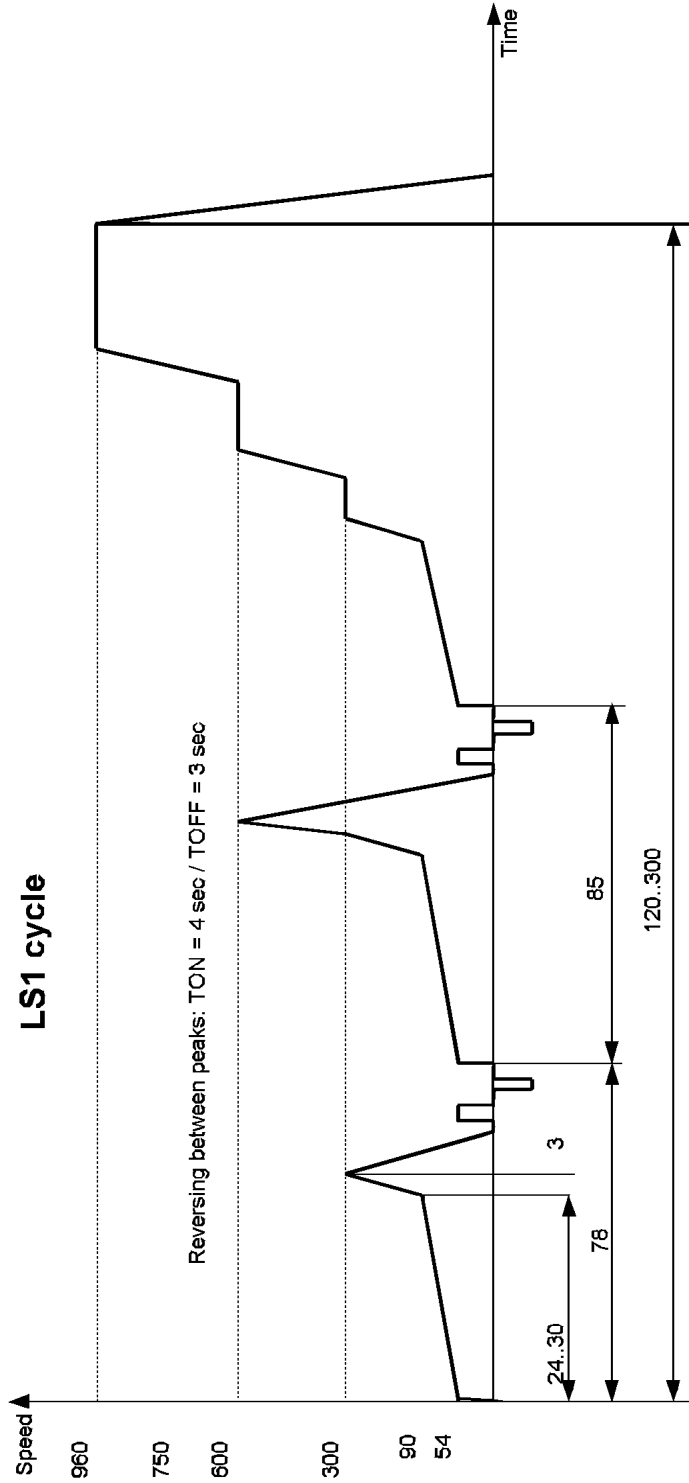

Nr of repeats in case of unbalance : max. 2 per ramp
The duration of the spinning is increased with the time necessary for the repetitions

Program chart

Soap dispenser: 4(3) chambers

Wash cycles / Spin cycles

A4

OMEGA

ES cycle

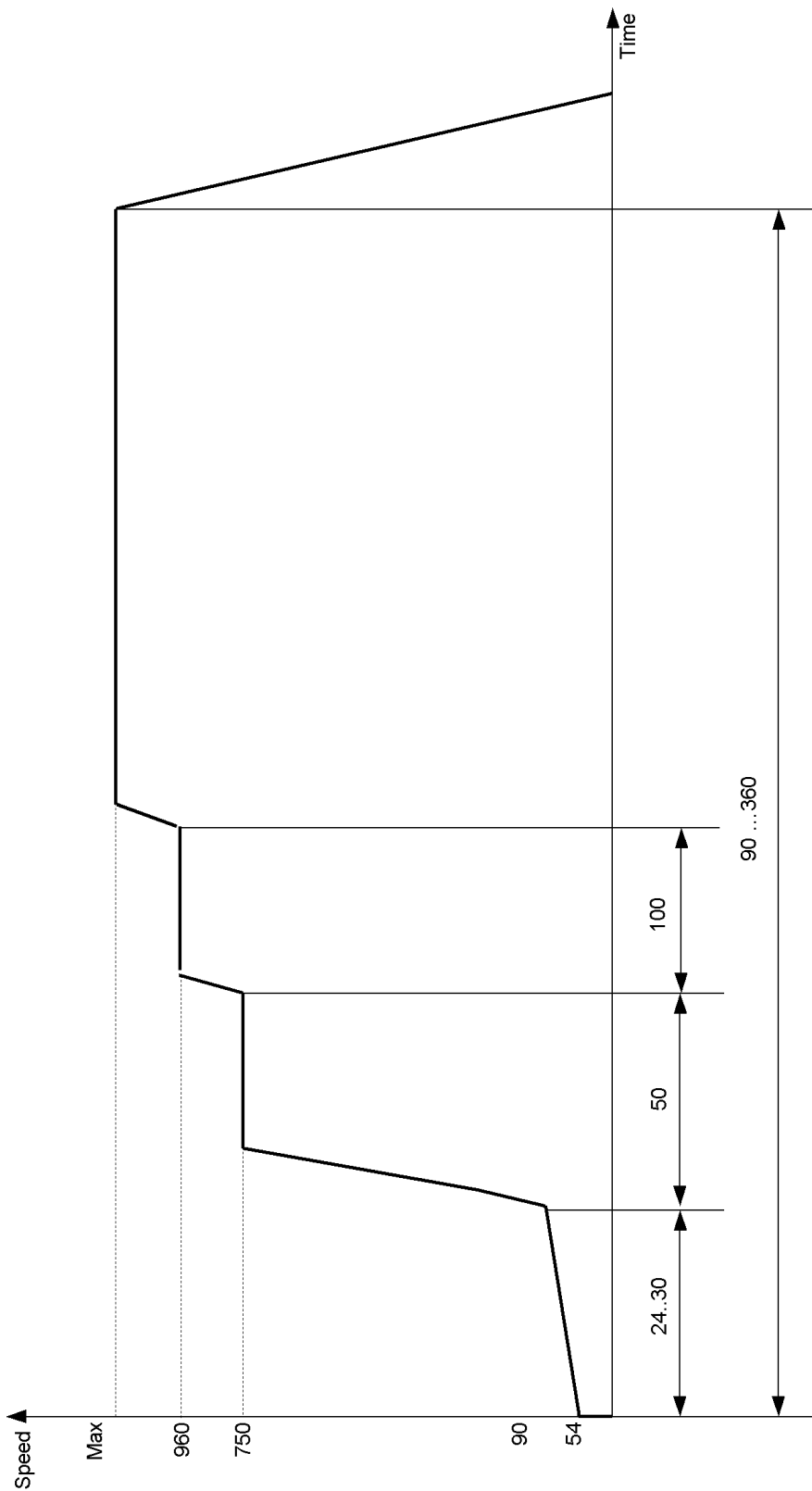

Nr of repeats in case of unbalance : max. 10

Nr of repeats in case of foam: max. 3

In the cycles WOOL and HANDWASH we do not have repeats.

The duration of the spinning is increased with the time necessary for the repetitions

A4

Text/Legend

OMEGA A4 Test Flow Soap dispenser: 4 (3) chambers

- | | | | |
|---|------------------------|--|--|
| 1 | Select program | Drain | |
| 2 | Start Test Program | press prewash option 4 times during 5 sec. | |
| 3 | Indication elements WH | LED Rest Time
LED Water Tap
LED Start | Indicates current program step
BLINK
ON |
| | Indication elements BK | DIGITS Rest Time
LED Water Tap
LED Start
LED Program Flow | Indicates current program step
BLINK
ON
BLINK |
| 4 | Go to next step | Push prewash option 2 times | |
| 5 | Finish test program | Move the program selector from the DRAIN position | |

Attention: Use the test program only without laundry!

Test step	Indication Whirlpool	Function	Duration	Checked	Drum rhythm
	120 80 60 45 30 15 5 0				
C0	● ○ ○ ○ ○ ○ ○ ○	Lock the door	Until the door locked	Door lock function Drum Up Switch	
C1	○ ● ○ ○ ○ ○ ○ ○	Fill, current dispencer position	until level 1 is reached		
C2	○ ○ ● ○ ○ ○ ○ ○	Move dispencer motor to Prewash		Dispencer	
C3	○ ○ ○ ● ○ ○ ○ ○	Fill (cold + hot)	N1 + 30"		
C4	○ ○ ○ ○ ● ○ ○ ○	Movement	60"	Motor	Drum CW 54 rpm
C5	○ ○ ○ ○ ○ ● ○ ○	Wash + Heat	max 50° + 1 min	Heater	Drum CW 54 rpm
C6	○ ○ ○ ○ ○ ○ ● ○	Drain	L1		Drum CW 54 rpm
C7	○ ○ ○ ○ ○ ○ ○ ●	Ramp	30"	Motor	Drum CCW Ramp 54.90 rpm
C8	○ ○ ○ ○ ○ ○ ○ ●	Spin (max speed)	60"	Motor	Drum CCW Max speed

If failure occurs The test program is stoped
Buzzer will beep 30 "
Speed LEDs are flashing
Failure indication on RestTime digits and/or temperature digits see next page

Text/Legend

OMEGA		A4	Test Flow		Soap dispenser: 4 (3) chambers	
Indication BK	IndicationWH				Detected failure	To be checked
	8h	6h	4h	2h		
F H	●	○	○	○	No water inlet	Water Tap / Valve / Flowmeter / Pressostat
F A	○	●	○	○	Aquastop failure	Aquastop switch
F P	●	●	○	○	Drain failure	Drain pump / Pressostat
F 4	○	○	●	○	Temperature failure (no temperature increase)	Heater , NTC
F 5	●	○	●	○	NTC failure (SC / OC)	NTC
F 6	○	●	●	○	Tachometer failure (no motor movement detected)	Motor; Tachometer
F 7	●	●	●	○	Triac short circuit detection	Control unit, Motor
F 8	○	○	○	●	Heater failure (no feedback on Heater safety)	Heater , Control Unit
F 9	●	○	○	●	Overflow failure	Pressostat
F 11	●	●	○	●	Communication failure	Control unit
F 12	○	○	●	●	Heater safety failure	Heater, Control unit
F 13	●	○	●	●	Water distributor failure	Distributor
F 14	○	●	●	●	EEPROM failure	Control unit
F 15	●	●	●	●	DrumUp failure	Drum Up sensor

In the failure state all actuators are switched OFF. The mains relays are opened.
Exception: During Aquastop/ overflow failure the Drain Pump is switched ON.

The ERROR state is canceled if we set the selector to OFF position.

Text/Legend

OMEGA A4

General Data Service

Soap dispenser: 4(3) chambers

Failure detection:

Detected in step	Description	Detection time	Indication
FILLING	no flowmeter pulses detected at the beginning of the step	15"	FH
FILLING	IF theLevel1 is not switched ON after a certain time	8 min	FH
ALL	If the Aquastop switch = ON: {Drain Pump = ON; Wait 60"} If Aquastop switch = ON {Drain Pump = ON ; Failure Mode}	60"	FA
ALL	If the Overflow contact = ON: {Drain Pump = ON; Wait 60"} If the Overflowcontact = ON {Drain Pump = ON ; Failure Mode}	60"	F9
DRAINING	If the level 1 is not switched OFF after 4 min of draining.	4 min	FP
HEATING	No water temperature increase during 10 min	10 min	F4
HEATING	NTC value = 0 // NTC values > 36 kOhm	10"	F5
HEATING	Heating element interrupted (not connected)	10"	F8
ALL (except HEATING)	Heating relay sticked closed Heater sc to ground	10"	F12
ALL	No tacho signal. Failure is declared after 2 trials.	2"	F6
ALL	Triac short circuit detected. Failure is declared after 2 trials	2"	F7
FILLING	No(Wrong) feedback from the dispencer contact during movement of the Dispencer.	5min	F13
ALL	Wrong data read from internal EEPROM	30"	F14
WHTEST	no drum up signal detected during step C0 of WH test program	3"	F15
ALL	No communication between Main microcontroller and motor microcontroller	3min	F11
SPINNING	IF the contact FOAM = ON then Stop spinning; Drain until the LevelFoam contact = OFF. Reset timing. Restart current peak . Max. 3 repeats		
SPINNING	IF the contact DoorLock = OFF (door not locked) then no Pinning performed		
HEATING	IF the contact DoorLock = OFF(door not locked) then Max temperature = 40°		

Text/Legend

Timer fully electronic (Front- and Toploader) 230 V, 50 Hz

- AQ2 aquastop switch
- OA8 control unit, unser IO
- DS2 door switch (safety)
- DP2 drain pump
- DU3 drum up
- HE2 heating element
- IF2 interference filter
- M7 motor drive
- D16 switch / motor distribution
- PR6 pressostat
- DL3 door switch (lock)
- FM3 sensor, flow
- TH2 sensor, temperature
- VC3 valve, cold fill
- VH3 valve, hot fill
- PI4 program, input

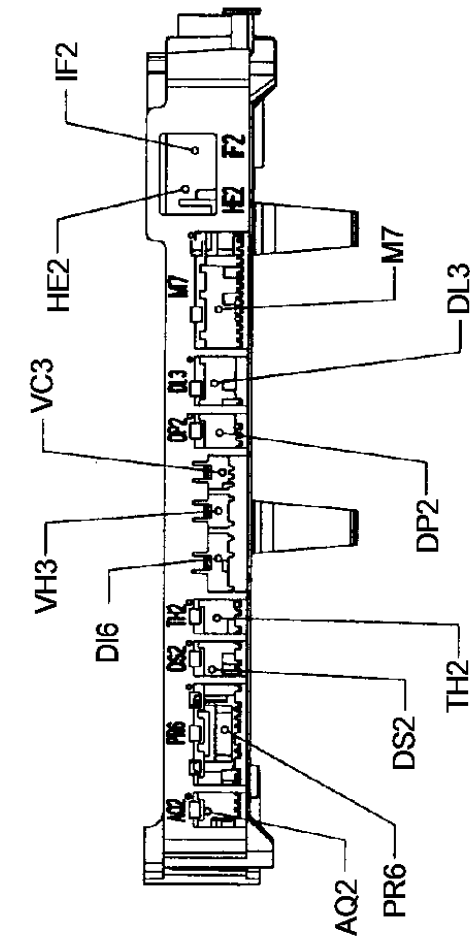
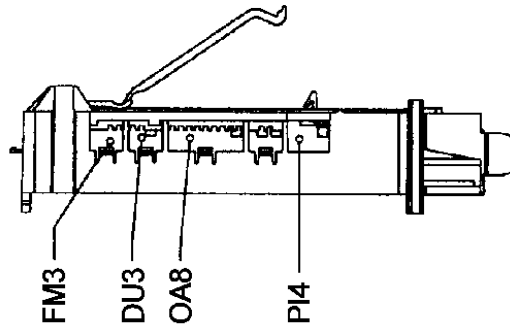
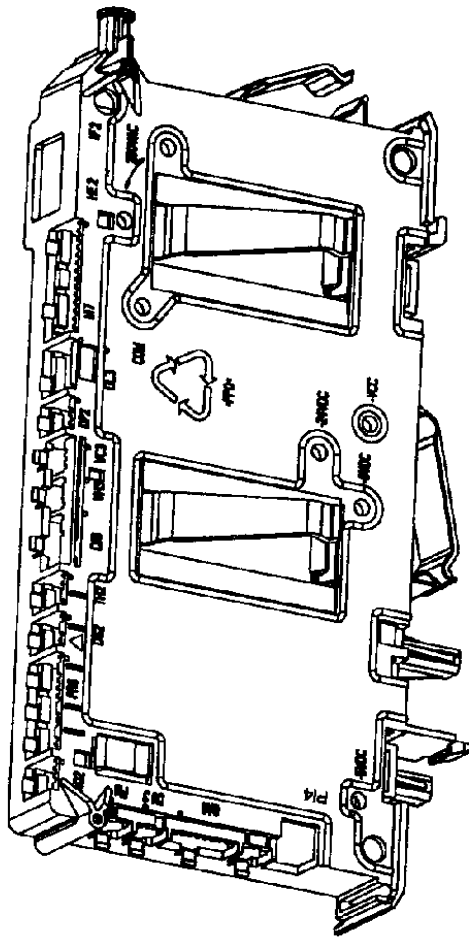

Test points
 (program selector "on")
 - 5 VDC - COM = - 5 V
 - 8 VDC - COM = - 8 ... - 10 V
 - 24 VDC - COM = - 22 ... - 27 V

Test points
 (program selector "off")
 - 5 VDC - COM = 0 V
 - 8 VDC - COM = - 8 ... - 10 V